

# DESIGN GUIDE

HIGH-DENSITY MOBILE STORAGE SYSTEMS

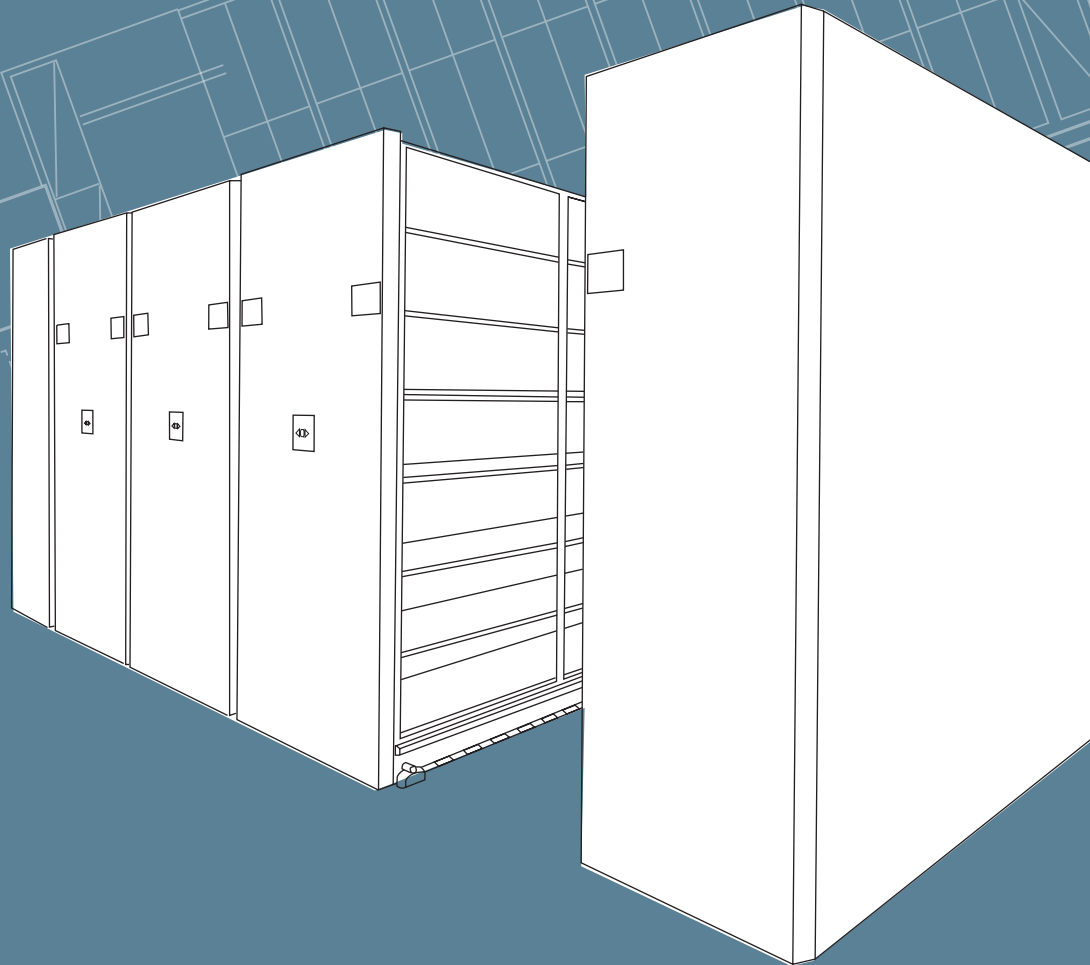

When you choose Spacesaver, you gain a partner who will work with you every step of the way—from pre-contract through final evaluation. We customize solutions for any and all facility storage requirements. The versatility of the system makes it possible to mount virtually any type of filing or storage equipment on our carriages. That, plus a wide range of styles, colors and configurations, gives you design options limited only by your imagination. With more than 250,000 successful installations, Spacesaver is North America’s leading manufacturer of high-density mobile storage systems for office, institutional and industrial applications. There’s no better storage solution than Spacesaver.

Benefits include:

- Up to 100% greater utilization of space
- Uncompromising user safety
- Secured access
- Compliance with all government mandates
- Unlimited design flexibility

Double the capacity of existing space. . .or save half the space. Spacesaver systems give you 100% greater storage capacity or a 50% reduction in floor space. How? The need for fixed aisles is eliminated. You simply push a button or turn a handle to open an aisle where you want it.



## THE SPACESAVER CONCEPT

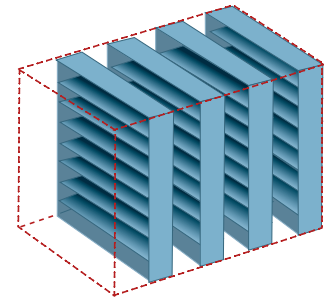

Traditional Static Shelving. Floor space is wasted in aisles.

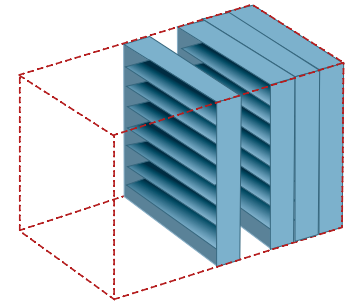

Same Capacity as Static Shelving in half the floor space.

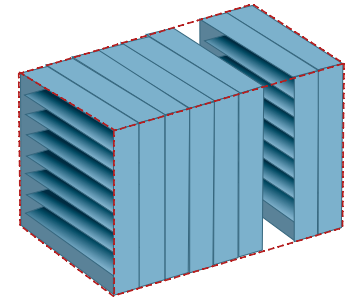

Double the Capacity in the same Floor Space

# COMPARISON

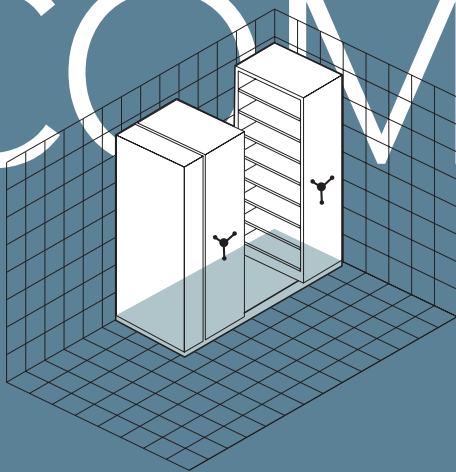

### SPACESAVER MOBILE SYSTEM

54.6  
Filing/Storage Inches/Sq. Ft.  
(2 Moveables +1 Stationary)  
1,360 Linear Inch Capacity  
24.9 Sq. Ft. of Floor Space

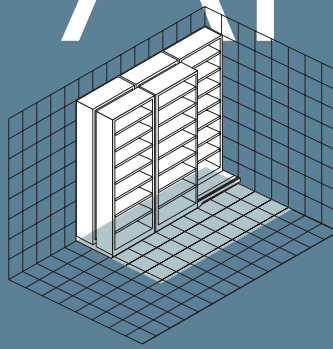

### 39.0 LATERAL SLIDING SHELVES

Filing/Storage Inches/Sq. Ft.  
(5 Eight Tier Sliding Shelves)  
1,360 Linear Inch Capacity  
34.9 Sq. Ft. of Floor Space

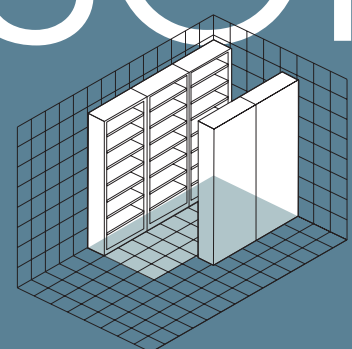

### 36.6 OPEN SHELVING

Filing/Storage Inches/Sq. Ft.  
(5 Eight Tier Shelf Files)  
1,360 Linear Inch Capacity  
37.5 Sq. Ft. of Floor Space

# FLEXIBILITY

Spacesaver offers a range of system control options. To demonstrate the flexibility of Spacesaver Mobile Storage Systems, illustrated below are three different density configurations designed for the same architectural space. Note especially, the handling of the column obstruction in each and how density increases as we move from manual to mechanical assist and finally to powered system control.

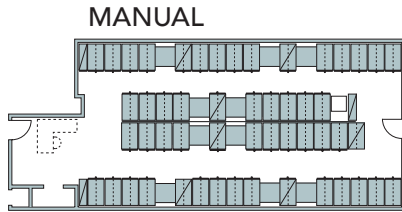

Up to 16' (4.8 m) long standard. Easy, frictionless movement for smaller applications. Four rows of 4' (1.2 m) long manual units with two entry corridors. Total = 3,424 Nominal Shelf Feet (1,043 m)

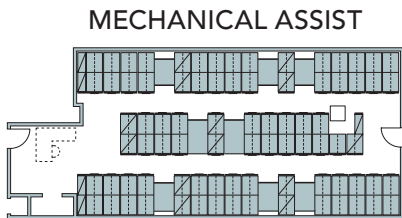

Up to 45' (13.7 m) long standard. Three-spoke operator allows one pound of effort to move maximum of 4,000-pound load. Three sections of larger capacity units and two entry corridors. Total = 4,152 Nominal Shelf Feet (1,265 m)

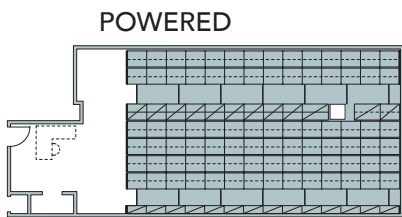

Programmable Up to 81' (24.6 m) long standard (longer available). Mobile app and programmable options available. Maximum density with minimum space needed for aisles. Total = 4,976 Nominal Shelf Feet (1,516 m)



Spacesaver gives you more filing/storage inches per square foot of valuable floor space. Compare for yourself.

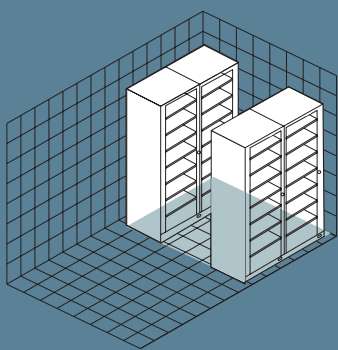

**33.6** **ROTARY SHELVING**  
 Filing/Storage Inches/Sq. Ft.  
 (4 Rotary Shelves)  
 1,536 Linear Inch Capacity  
 45.7 Sq. Ft. of Floor Space

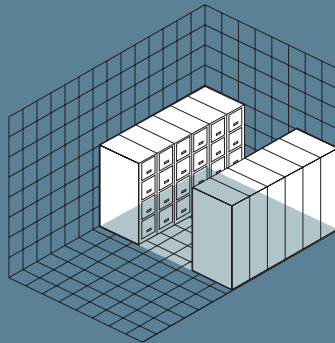

**20.7** **4-DRAWER CABINETS**  
 Filing/Storage Inches/Sq. Ft.  
 (Twelve 4-Drawer Cabinets)  
 1,152 Linear Inch Capacity  
 55.6 Sq. Ft. of Floor Space

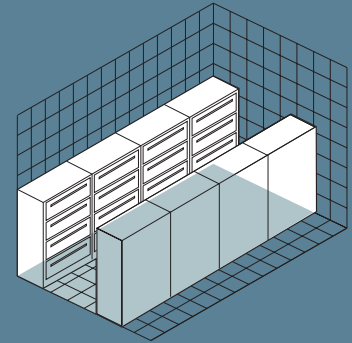

**16.7** **LATERAL FILES**  
 Filing/Storage Inches/Sq. Ft.  
 (Eight 4-Drawer Files)  
 1,440 Linear Inch Capacity  
 86.3 Sq. Ft. of Floor Space

## DESIGN CONSIDERATIONS

These guidelines, and the specifications that follow, will get you started designing a Spacesaver Mobile Storage System for your building project. Our Spacesaver design team is ready to assist you with specific recommendations. Call 1.800.492.3434 or the contact us section on [www.spacesaver.com](http://www.spacesaver.com).

### CONTROLS

You'll choose manual, mechanical assist or powered controls based on your individual customer's needs. The TUSC™ Control app is compatible only with powered systems.

### CLEARANCES

All systems require a minimum clearance of 2" (50 mm) from the back wall and 3" (76 mm) from the ceiling or any other protrusions. Additional clearance may be required for sprinkler heads, smoke alarms, by powered systems or by local fire and building codes. (Follow local codes.)

### AISLE WIDTHS

When planning aisle space for a bank of carriages, add a minimum 1-1/2" (38 mm) to the depth of each shelving section—i.e. 24" (609 mm) deep shelving will require 25-1/2" (648 mm) of floor space. This helps maintain required aisle width for a bank of carriages given architectural restrictions. Check local accessibility regulations (ADA) for additional requirements. Additionally, add 3" (76 mm) to overall carriage length (including handle) of shelving range for manual and powered systems, 6" (152 mm) for mechanical assist systems. Also note that there is a slight "growth factor" for shelving width which may become significant for multiple shelving sections on long carriages.

### FACE PANELS

In addition to standard laminate, we offer an extensive choice of colors and finishes, including high-pressure laminates, fire-retardant laminates, wood veneer and steel.

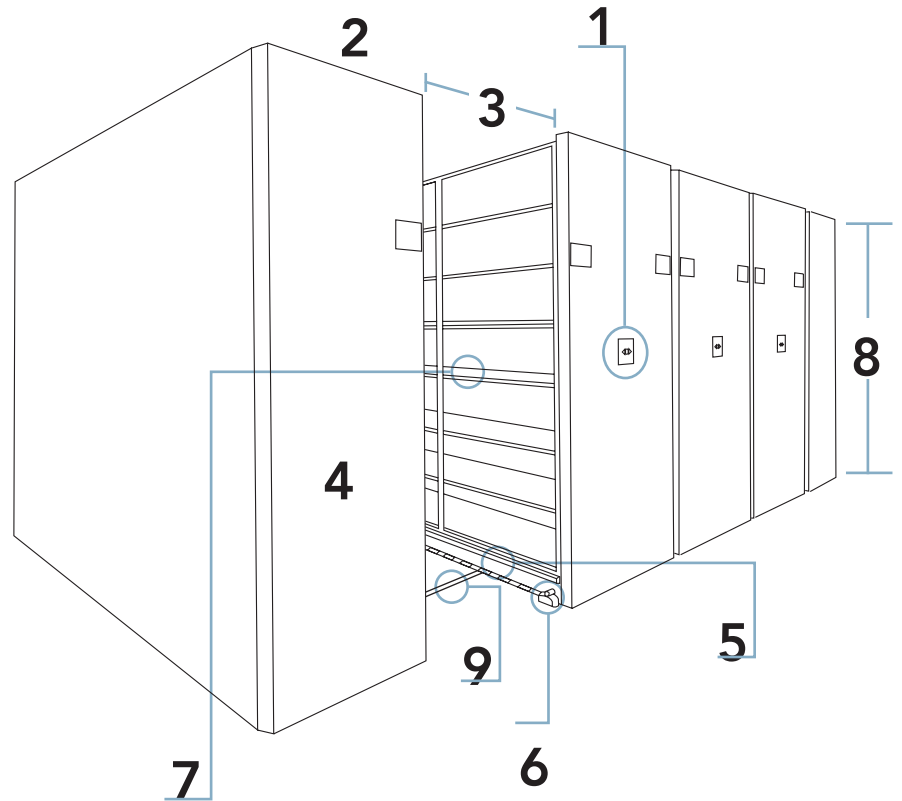

### CARRIAGES

Carriages are welded "uniframe" steel or aluminum construction and engineered to meet your specific load requirements. A minimum 3/4" (19 mm) retaining lip holds shelving or other storage housing in place.

### SAFETY FEATURES

Our safety features are virtually unparalleled in the industry. See opposite page.

### SHELVING

We offer four-post, case-type and cantilever shelving for both mobile and stationary applications, although our systems are designed to accommodate virtually any kind of new or existing shelving, cabinets or other storage housing.

### HEIGHTS

Depending upon the components required for your application, the track, wheel and carriage elements will add approximately 6 to 9" (152–228 mm) to the height of the storage equipment used.

### STRUCTURE RAILS

We offer a variety of rails and structural rails that can be employed as flooring members to meet load requirements or overcome structural constraints. Rail size, spacing and orientation are flexible to accommodate the loads to the building structure. Patented anti-tip systems meeting all present seismic codes and regulations are available.

# SAFETY

Safety has been paramount in Spacesaver's engineering from the very beginning. As a result, we've pioneered virtually every significant safety feature in the industry. Any of our systems can be designed to close and lock when not in use. All of our powered systems—many of which can also be programmed for controlled, selective access—are UL system listed and CSA approved.

The safety system you choose will depend upon your individual customer's needs, the type of controls selected and whether the system will be accessed by the general public or restricted to trained personnel. We urge you to let us do a customer needs analysis and make recommendations for your individual projects.

## ZERO-FORCE SENSOR (ZFS)<sup>®</sup>

Provides a completely passive method of protecting people and objects in the open aisles of all programmable electric systems. It prevents the system from moving when someone or something is in the aisle, and automatically resets when the aisle is cleared.

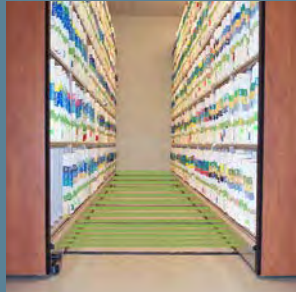

## MECHANICAL SWEEP

Functions by applying pressure to the sweep located along the length of the carriage. If a carriage begins to move while you are in the aisle, it can be stopped by depressing the metal sweep plate with your foot in the area defined by the red and white safety tape.



## SAFETY SWEEP

A photoelectric beam, running the full length of every carriage, protects users, as well as any object that may have fallen to the floor, by stopping carriage movement upon contact. Mechanical sweep also available.

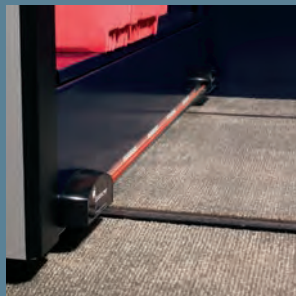

## aisle-ENTRY SENSOR

A photoelectric beam that crosses each aisle. Entering an open aisle will break the beam and prevent the system from moving. Entering an open aisle will prevent the system from moving until the system is reset. Entering a closing aisle breaks the beam stopping the system movement.



## ANTI-TIP PROTECTION

With anti-tip devices that are approved even for the most earthquake-prone areas of the country, stability is designed right in.

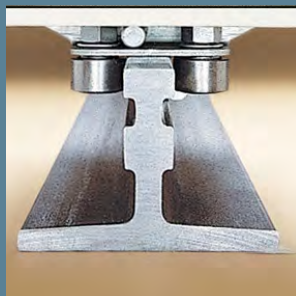

## PROGRAMMABLE AISLES

Automatic system movement options let you position carriages just where you want them. Automatically open a heavily used aisle. Close all aisles. Open aisles evenly for ventilation. Open each aisle in sequence. Even move all carriages to predetermined positions when the fire alarm system is activated.



## aisle LIGHTING

For operator safety and convenience, overhead lighting is available for all Spacesaver systems. It can be interfaced with any system to activate automatically when anyone enters an aisle or it can be tied into your building's security system.





## ADDITIONAL SERVICES

Spacesaver also offers a number of brochures, guidebooks and design aids for both general and specific applications. Contact Spacesaver for complete CSI formatted specifications. And, if you'd like to visit a Spacesaver installation(s) in your area, your Spacesaver Area Contractor can make the arrangements. For more information, call 1-800-492-3434.

### INSTALLATION SERVICE

For details on delivery and installation, contact Spacesaver for your local Area Contractor. Our network of 100 North American service locations assures you of prompt, courteous service and expert installation by technicians with years of factory-trained experience. Call for contractor and service at 800.492.3434.

### WARRANTY

Spacesaver systems carry a five (5) year warranty against defects in material or workmanship. This warranty is subject to Spacesaver's standard terms and conditions of warranty. See a certificate of warranty/system acceptance form for all warranty details and terms that apply to Spacesaver products.

### EDUCATIONAL SEMINARS

Learning units may be earned through Spacesaver's pre-approved AIA/CES and IDECE registered seminars. For a full list of seminars visit our website link: <http://www.spacesaver.com/Spacesaver/Design/Continuing-Education.htm>





Bradford Systems  
945 North Oaklawn Avenue  
Elmhurst, IL 60126  
800.696.3453  
[www.bradfordsystems.com](http://www.bradfordsystems.com)



Spacesaver Corporation  
1450 Janesville Avenue  
Fort Atkinson, WI 53538-2798  
800.492.3434  
[www.spacesaver.com](http://www.spacesaver.com)