

EZ Rail™ element

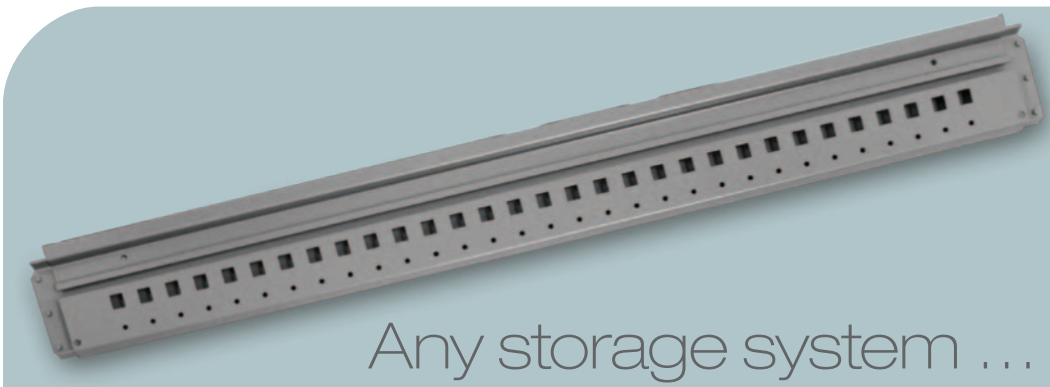

... is suddenly more **FLEXIBLE.**

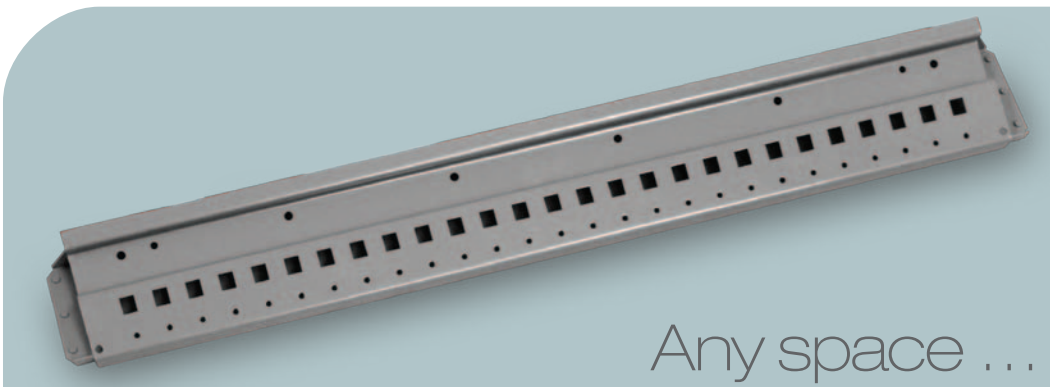
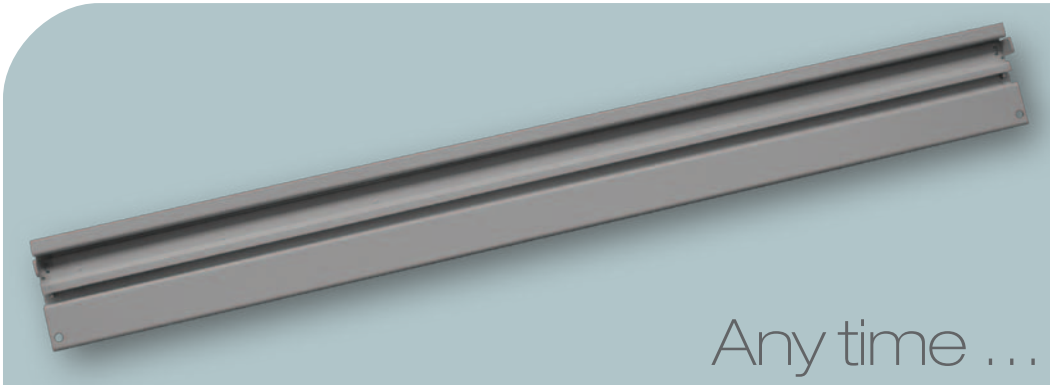

key features

- Simple one-piece design
- Installs without fasteners
- Two versions allow horizontal or sloped installation of a variety of industry standard hanging bins
- Horizontal version fits a variety of pegboard and slatwall accessories
- Horizontal version fits many UWR storage system barrel and pistol supports



Fits industry standard hanging bins and standard pegboard and slatwall accessories



Design variations for horizontal or 17-degree sloped installation

EZ Rail™ element

FOR 4-POST, CASE AND UWR™ STORAGE SYSTEMS

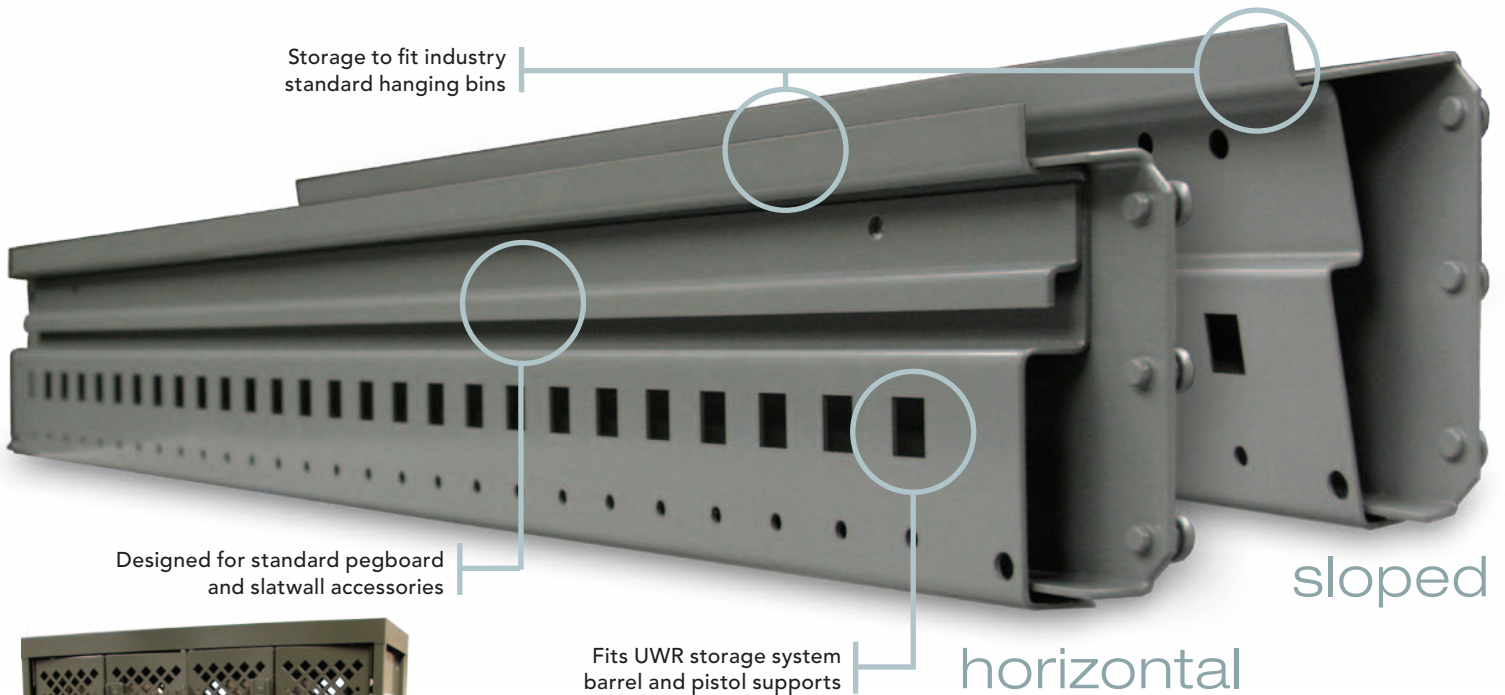

Storage to fit industry standard hanging bins

Designed for standard pegboard and slatwall accessories

Fits UWR storage system barrel and pistol supports

sloped

horizontal



Easily changes between bins, barrel supports and more

EZ Rail™ element provides innovation ... and opportunity

EZ Rail™ element adds flexibility to new installations. It offers renewed utility to existing storage. And it creates opportunities for creating enhanced, superior functionality in a range of applications.

Now you can improve, adjust, update and adapt to changing storage requirements.

The ideal storage solutions should adapt perfectly to today's needs, while offering the flexibility to cost-effectively transform to future requirements. New patent-pending EZ Rail element brings modern storage closer to that ideal.

Because EZ Rail element is compatible with Spacesaver storage systems as well as many other brands, it can provide maximum value by extending the useful life of current installations. And when specified for new storage, EZ Rail element adds an unprecedented layer of flexibility – a built-in responsiveness to unanticipated changes. It all adds up to more storage options, better storage capacity, longer service life.

improve
adjust
update
adapt

EZ Rail™ element

FOR CANTILEVER AND FRAMEWRX™ STORAGE SYSTEMS

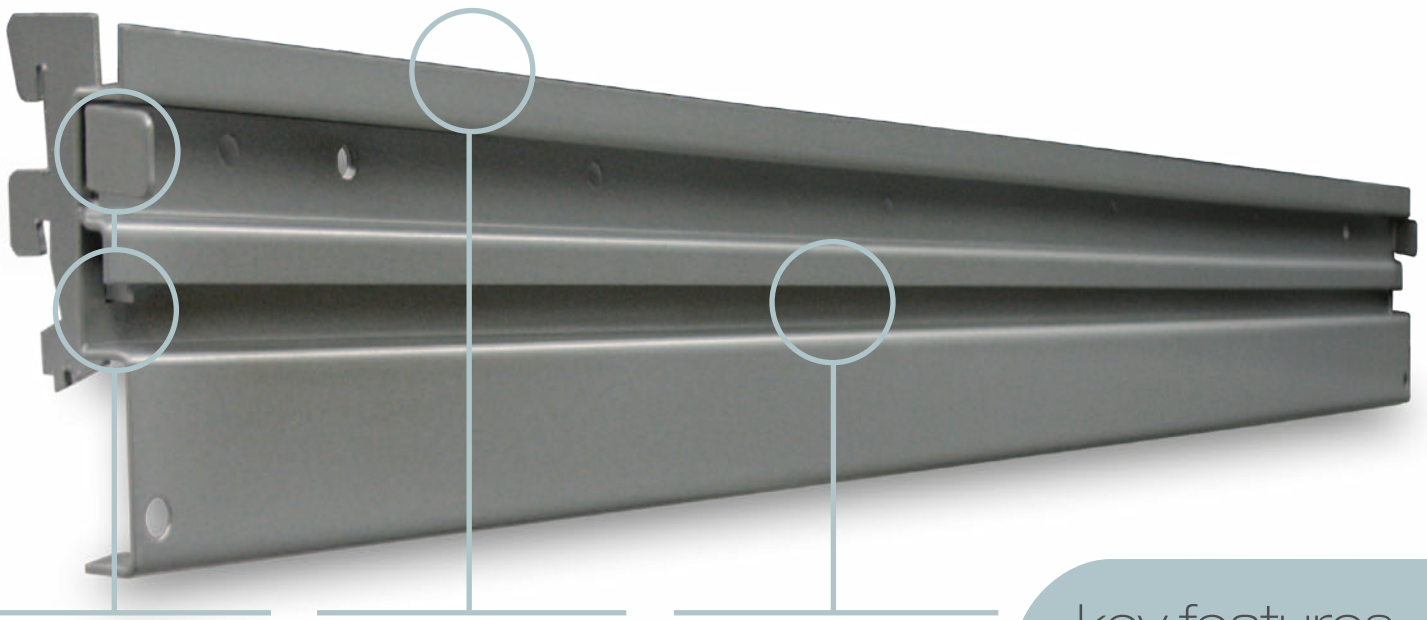

Built-in stops for bin, pegboard and slatwall accessories

Optimized storage fits industry standard hanging bins

Designed for standard pegboard and slatwall accessories



Exclusive mounting design allows both horizontal or 17-degree sloped installation





Fits industry standard hanging bins and pegboard and slatwall accessories

key features

- Simple one-piece design
- Installs without tools or fasteners
- Sizes optimized for bin storage plus standard frame widths
- Innovative design allows two installation angles with single rail
- Compatible with a variety of bins, pegboard and slatwall accessories

EZ Rail™ element

	Catalog No.	Width in. (mm)	Weight lbs.
FRAMEWRX™ STORAGE SYSTEMS & CANTILEVER SHELVING			
	One rail for both horizontal or 17-degree sloped applications	CBPR24	24 (610) 3.25
	40 lb. weight capacity	CBPR30	30 (762) 4.00
	Stores hanging bins, slat wall accessories and peg board hooks	CBPR337	33.7 (856) 4.50
	No tools or fasteners required	CBPR36	36 (914) 5.00
4-POST, CASE SHELVING, UWR™ & UWRmini™ STORAGE SYSTEMS			
HORIZONTAL			
	Horizontal hanging rail	4PUWRSRBH22	22 (559) 5.50
	125 lb. weight capacity	4PUWRSRBH24	24 (610) 6.00
	Stores hanging bins, slat wall accessories, peg board hooks and UWR components that utilize one row of slots	4PUWRSRBH30	30 (762) 7.50
		4PUWRSRBH36	36 (914) 9.25
	No fasteners required	4PUWRSRBH42	42 (1067) 10.75
		4PUWRSRBH48	48 (1219) 12.25
SLOPED			
	17-degree sloped rail	4PUWRSRBH22SL	22 (559) 5.88
	150 lb. weight capacity	4PUWRSRBH24SL	24 (610) 6.50
	Stores hanging bins up to 7" high	4PUWRSRBH30SL	30 (762) 8.25
		4PUWRSRBH36SL	36 (914) 10.00
	No fasteners required	4PUWRSRBH42SL	42 (1067) 11.75
		4PUWRSRBH48SL	48 (1219) 13.25

Technical Specifications

EZ RAIL™ ELEMENT FOR CANTILEVER AND FRAMEWRX™ STORAGE SYSTEMS

Accessory rail shall be of a one-piece design and containing a bracket on both ends, which is designed such that it enables the rail to be installed horizontal or sloped at a 17-degree angle without the need for any tools or fasteners. The rail shall provide both a mounting surface for industry standard hanging bins as well as a channel for mounting slat wall accessories and pegboard hooks. The rail shall contain features which prevent hanging bins and slat wall accessories from sliding or being pushed off the end of the rail. The rail is available in [24"] [30"] [33.7"] [36"] nominal widths. Weight capacity maximum 40 pounds.

EZ RAIL™ ELEMENT FOR 4-POST/CASE/UWR™ STORAGE SYSTEMS – HORIZONTAL MOUNTING

Accessory rail shall be of a one-piece design, and can be installed without any fasteners. The rail shall provide a mounting surface for industry standard hanging bins, a channel for mounting slat wall accessories and pegboard hooks, as well as slots for mounting all UWR™ components that utilize one row of slots for installation. The rail is available in [22"] [24"] [30"] [36"] [42"] [48"] nominal widths. Weight capacity shall be at least 125 pounds.

EZ RAIL™ ELEMENT FOR 4-POST/CASE/UWR™ STORAGE SYSTEMS – SLOPED MOUNTING

Accessory rail shall be of a one-piece design, and installed at a 17-degree slope without any fasteners. The rail shall provide a mounting surface for industry standard hanging bins as well as slots for mounting future accessories. The rail is available in [22"] [24"] [30"] [36"] [42"] [48"] nominal widths. Weight capacity shall be at least 150 pounds.



Bradford Systems
Corporate Offices
430 Country Club Drive
Bensenville, Illinois 60106

EZ Rail™

e l e m e n t

New EZ Rail™ element can help your storage keep pace with your needs.

From shelving to bins, from racks to hooks and hangers – your storage needs are constantly changing. Keeping up can be a headache as well as a real budget-buster. But now there's patent-pending EZ Rail™ element. It creates flexible storage solutions that adapt easily to your evolving requirements. You can use EZ Rail element to upgrade existing installations, to give new service life to "obsolete" shelving and to optimize new installations.

Flexible EZ Rail™ element offers advantages other storage solutions can't provide:

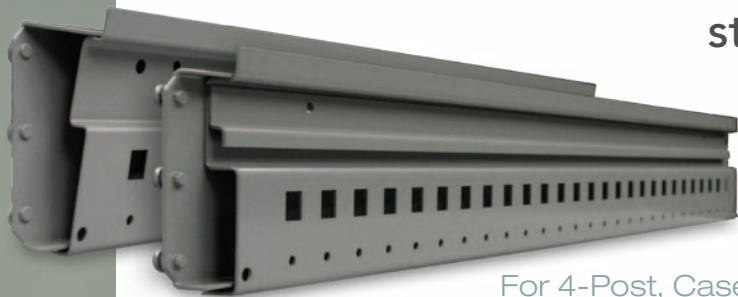

For 4-Post, Case and UWR™ storage systems

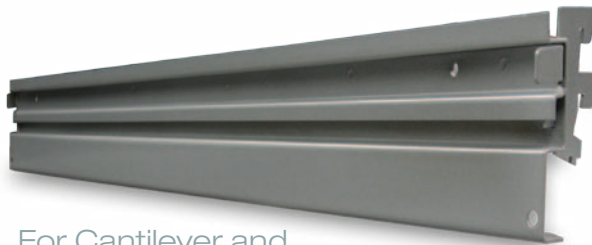

For Cantilever and FrameWRX™ storage systems

- Update your storage to meet changing needs
- Create easy access to most-used supplies
- Adapt storage areas to rapid stock turnover
- Display parts and accessories in custom configurations
- Make the most of limited retail space
- Simplify and streamline future changes
- Maximize storage efficiency and productivity



Tool storage using EZ Rail element and slatwall accessories on 4-Post



Athletic equipment storage using EZ Rail element and special accessories on 4-Post



Apparel display using EZ Rail element and slatwall accessories and FrameWRX™ storage systems



Retail items merchandising using EZ Rail element and pegboard hooks on FrameWRX™ storage system

EZ Rail element offers a long-term storage solution. Here's a storage system that adapts quickly – cost-effectively – to ever changing needs. And your storage options remain flexible, so future changes can be accommodated easily. Here's one solution that won't be obsolete tomorrow.



EZ Rail™
e l e m e n t

Here's how EZ Rail™ element helps healthcare provide for its future.



As healthcare practices evolve and improve, healthcare storage is in constant need of change. But this shouldn't mean constantly replacing equipment. Today's patent-pending EZ Rail™ element creates flexible storage solutions to meet evolving requirements. EZ Rail element offers optimum flexibility for new systems, or retrofitting of existing storage. Like the healthcare industry, EZ Rail element responds quickly to meet your changing needs.

EZ Rail element lets healthcare providers focus on what they do best; it's a storage system that adapts quickly – cost-effectively – to changing needs. And storage options remain flexible, so future changes can be accommodated easily.



Sterile supplies organized in color-coded bins on FrameWRX™ storage system

For 4-Post, Case and UWR™ storage systems



For Cantilever and FrameWRX™ storage systems



Exclusive mounting design allows both horizontal and sloped installation

Flexible EZ Rail element offers advantages other storage solutions can't provide:

- Retrofit 4-Post records shelving into supplies storage
- Outfit with pegs to store robot-ready medications
- Optimize space utilization in Pharmacy, Clean Room, Emergency ...
- Use color coded bins to organize/consolidate supplies
- Use at supply stations providing access to supplies when and where they're needed
- Maximize bin storage density, matching bin size to contents
- Reconfigure storage easily, whenever necessary



EZ Rail™

e l e m e n t

Here's how EZ Rail™ element helps storage solutions stay geared up.

The longevity of any piece of equipment is often determined by its flexibility. As military gear is upgraded, updated, and replaced, your storage has got to keep pace. New patent-pending EZ Rail™ element creates storage solutions that stay flexible as demands change. EZ Rail element is as adaptable to existing storage solutions as it is to new installations. Either way, it provides superior functionality and enduring flexibility.



For Cantilever and FrameWRX™ storage systems

For 4-Post, Case and UWR™ storage systems

EZ Rail element provides the ultimate in flexibility, so today's storage options can adapt to accommodate your needs tomorrow. Quickly. Easily. EZ Rail element offers a whole toolkit of solutions to make sure your unit is always geared up.

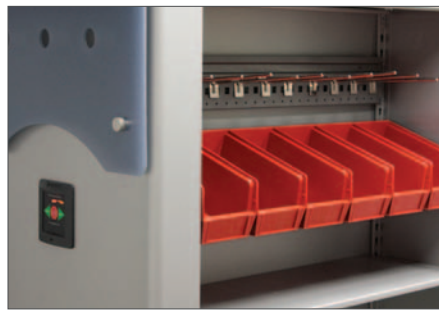

Fits industry standard hanging bins and pegboard and slatwall accessories



Easily changes between bins, racks, barrel supports and more



Flexible EZ Rail™ element offers advantages other storage solutions can't provide:

- Easily reconfigure your storage as your needs change
- Convert racks to storage for sensitive small parts, electronics, etc.
- Add secure, high density bin storage for optics and lasers
- Use color coded bins to organize/consolidate parts and accessories
- Build weapons storage from existing racks and shelves
- Conveniently position parts/tool storage above benches
- Maximize efficiency and functionality



EZ Rail™

e l e m e n t

New EZ Rail™ element can help save space as it rescues budgets.

Whether it's racks for weapons, shelves for evidence, or even bins for evidence processing supplies, your storage demands are constantly changing. This doesn't have to mean equipment replacement. New patent-pending EZ Rail™ element lets you customize your storage solutions- it works great for retrofitting existing racks and shelving. It also extends the service life of new installations. Either way, it offers optimized flexibility as well as superior functionality.



Evidence processing work station on FrameWRX™ storage system



For Cantilever and FrameWRX™ storage systems

For 4-Post, Case and UWR™ storage systems



Fits industry standard hanging bins and pegboard and slatwall accessories

EZ Rail element multiplies your options, so customizing storage solutions is simple and cost-effective. And because your choices stay flexible, any future demands can be met easily, within tight budgets. Here's a solution that won't be obsolete tomorrow.

Flexible EZ Rail™ element offers advantages other storage solutions can't provide:

- Upgrade 4-post shelving storage systems to meet changing needs
- Use color coded bins to organize/consolidate evidence processing
- Mix bin and rack storage for efficient space usage
- Build weapons storage from existing racks and shelves
- Optimize evidence storage capacity by easily changing bin size to match evidence stored
- Maximize resource utilization and functionality
- Low cost means almost everybody can fit EZ Rail element into their current budget

